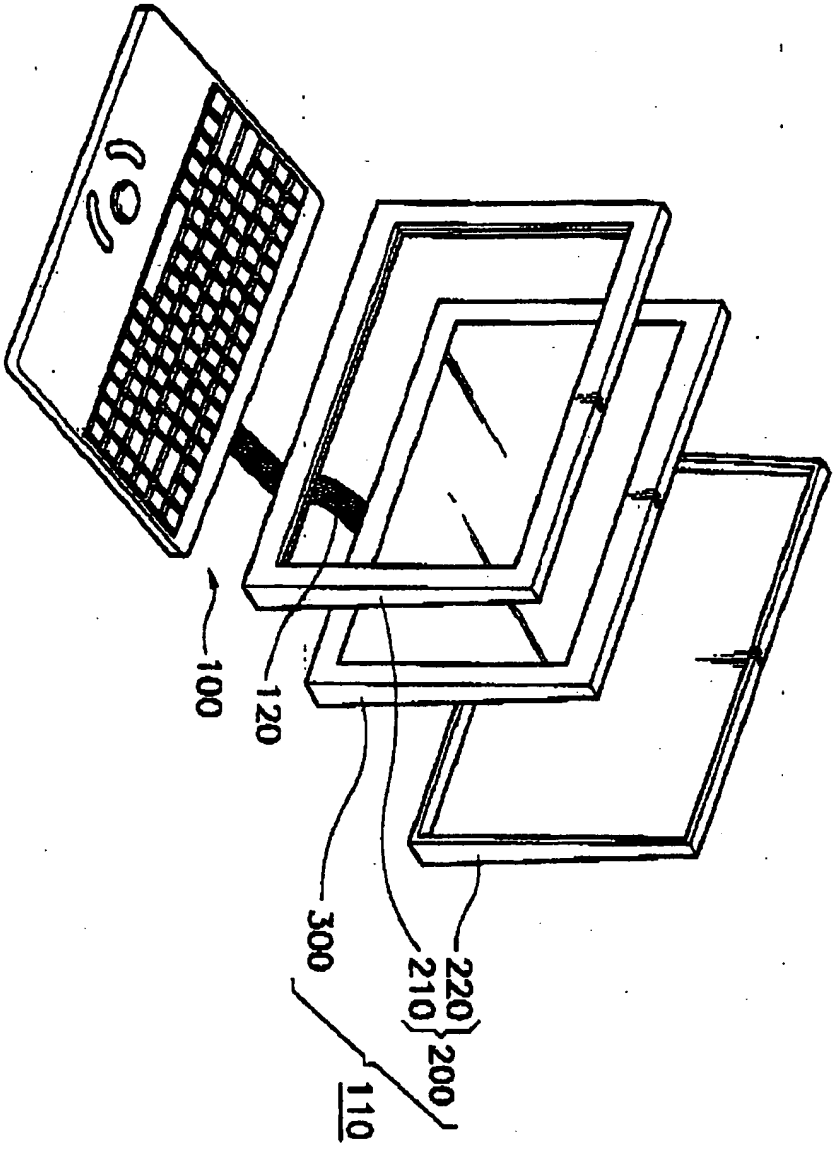
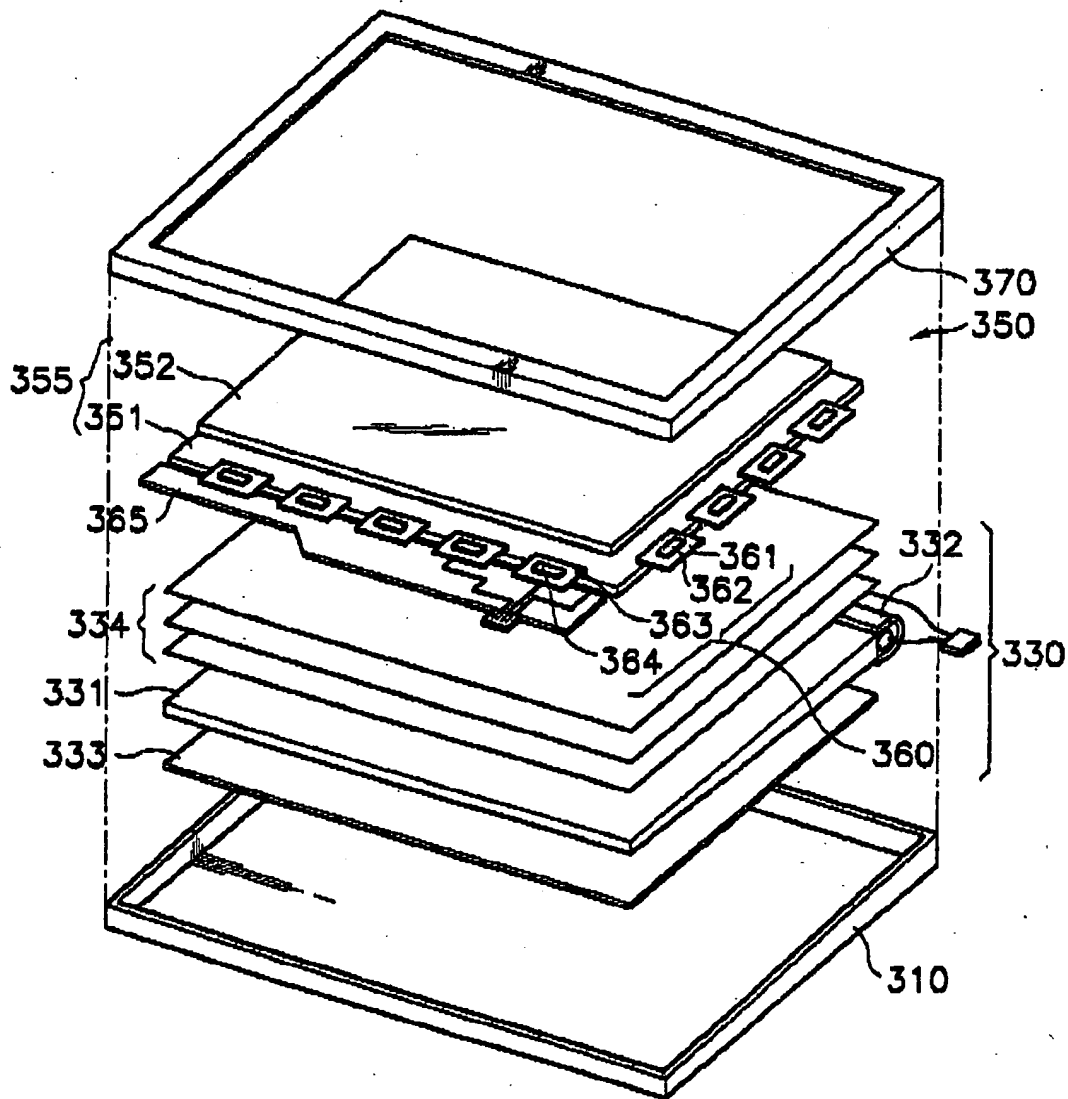

FIG. 1



09621825-072100

FIG. 2



DOT20:52B72960

FIG. 3

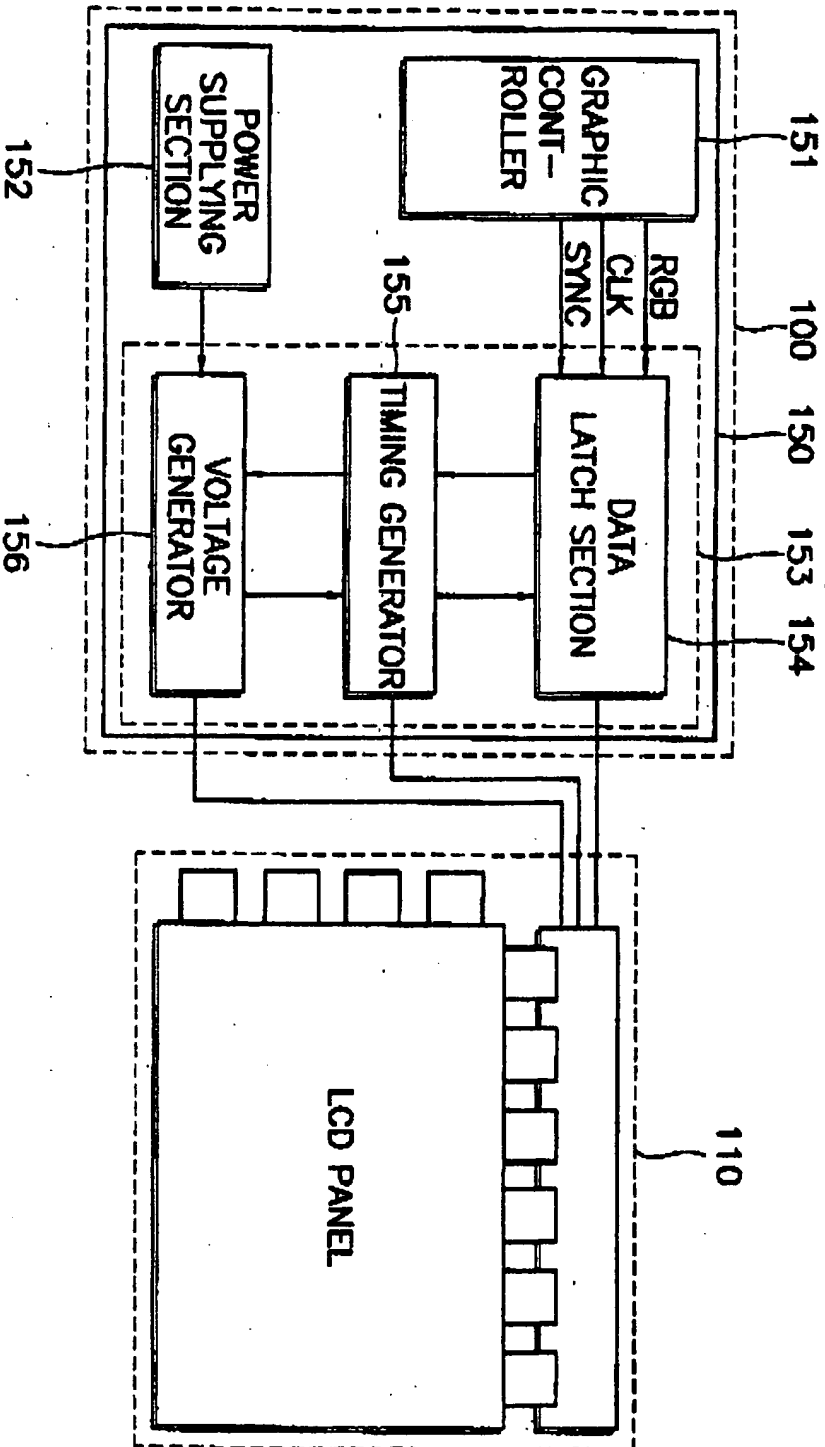
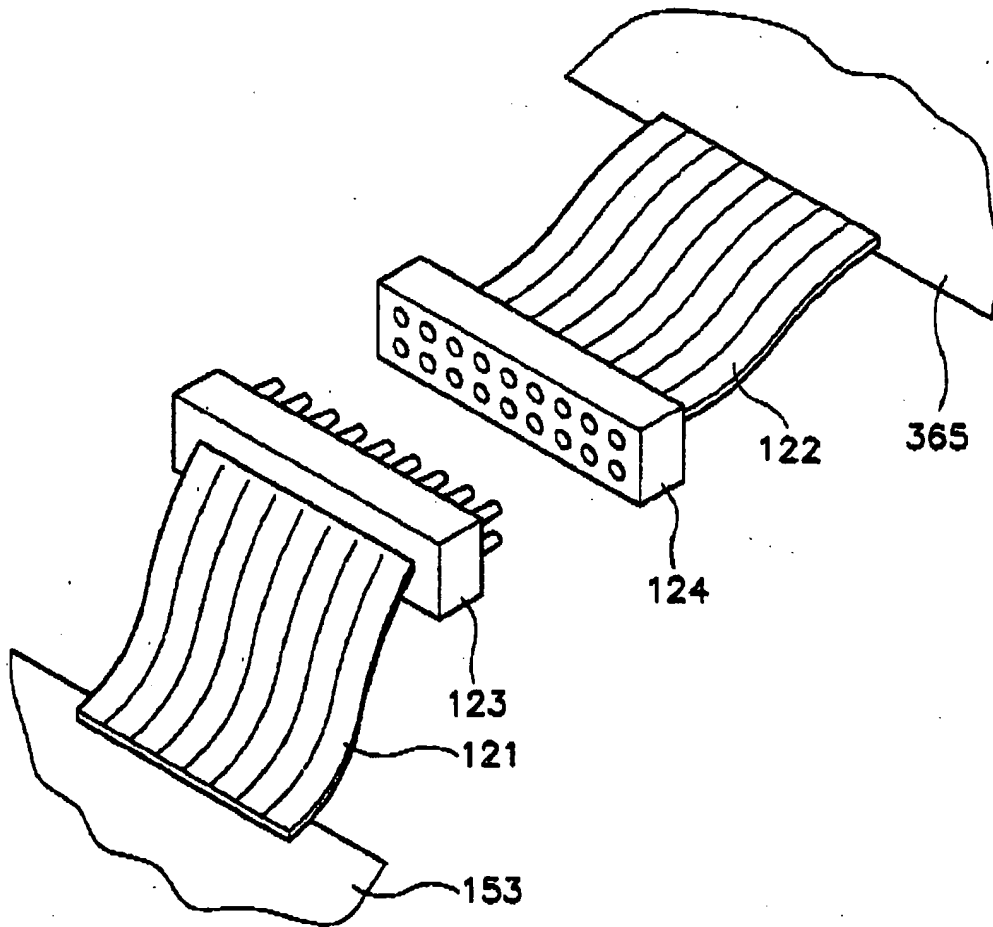
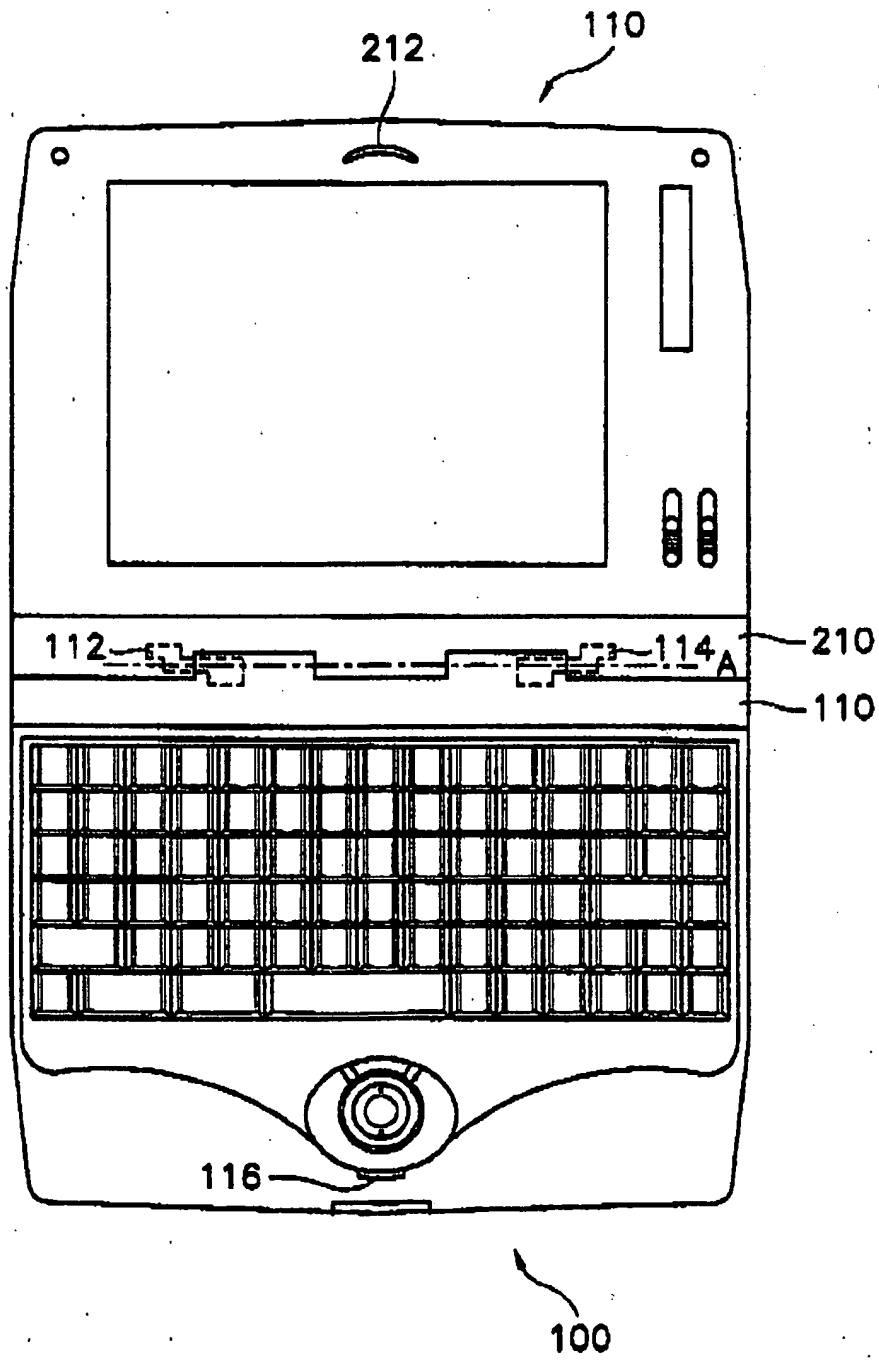

FIG. 4



DOT 2.0" SUB 2350

FIG. 5



007240" SUB2560

FIG. 6

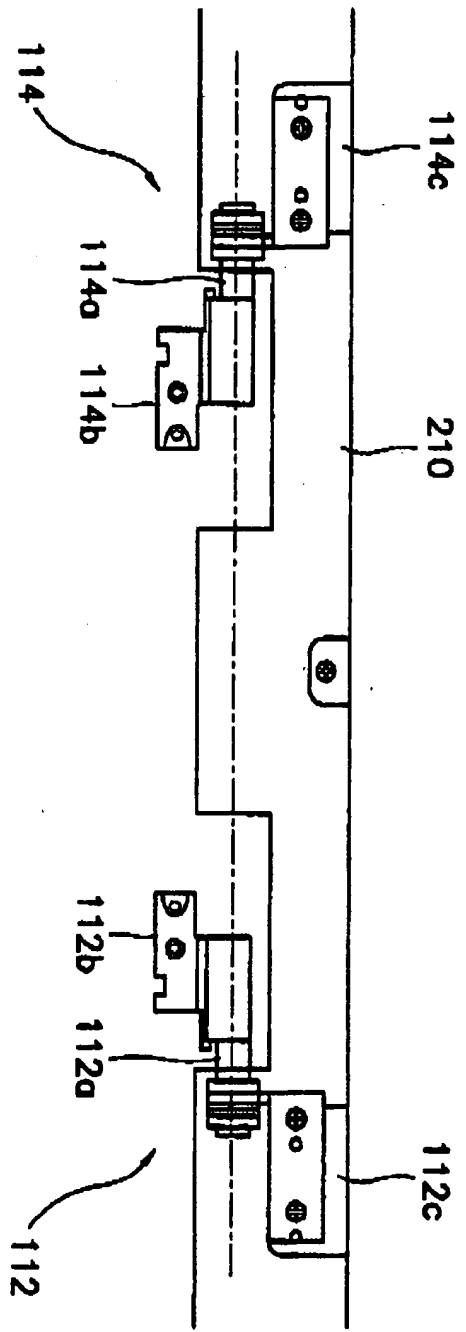
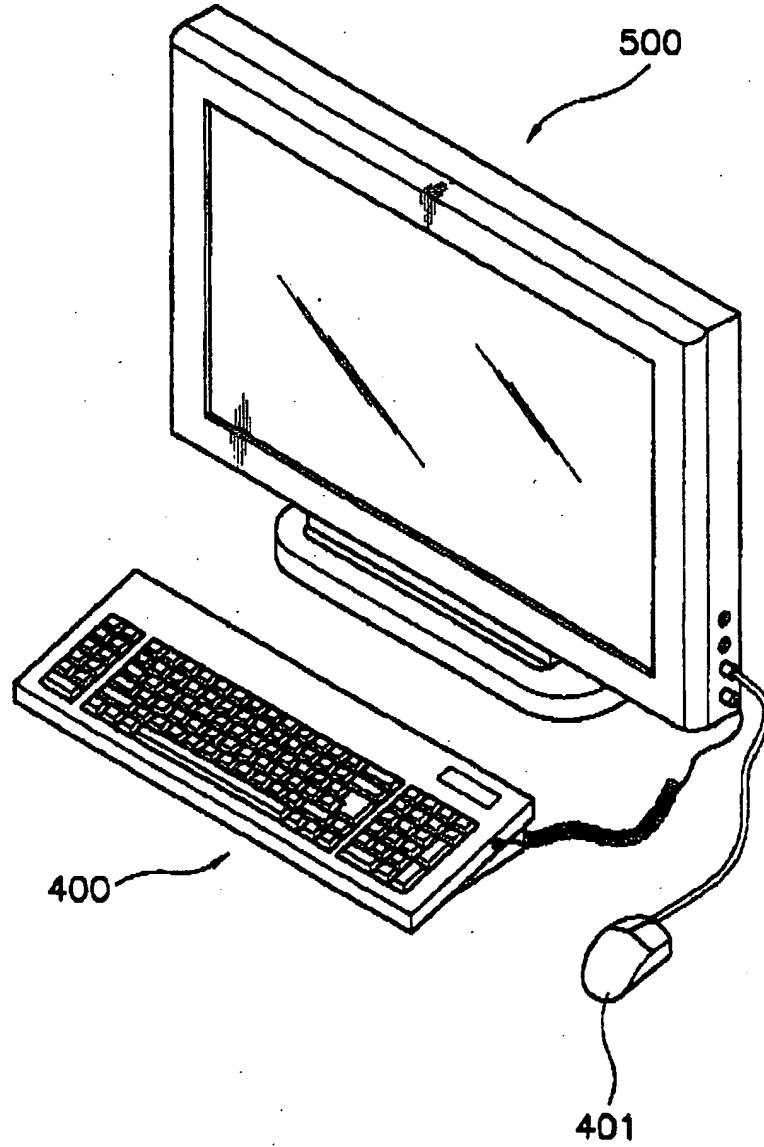

FIG. 7



DOT 2.0" SUB 2.560

FIG. 8

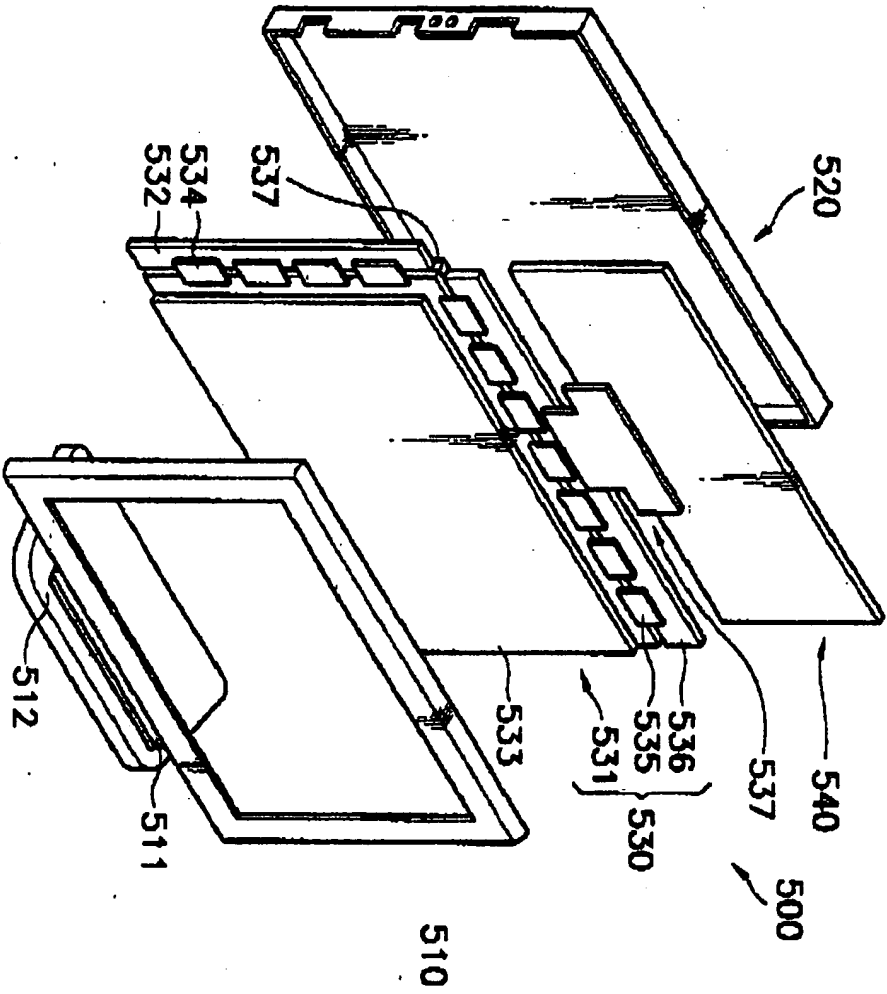
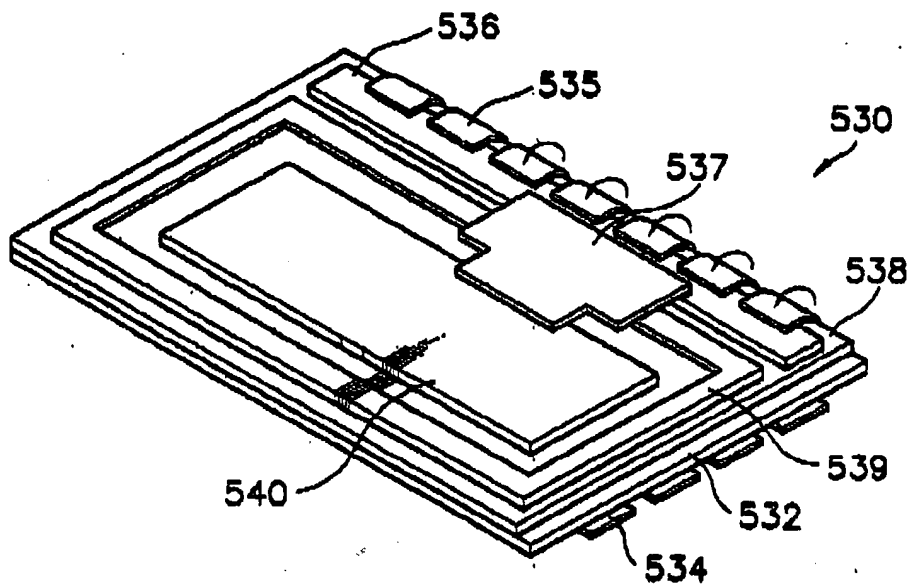



FIG. 9



007240\*528729150

FIG. 10

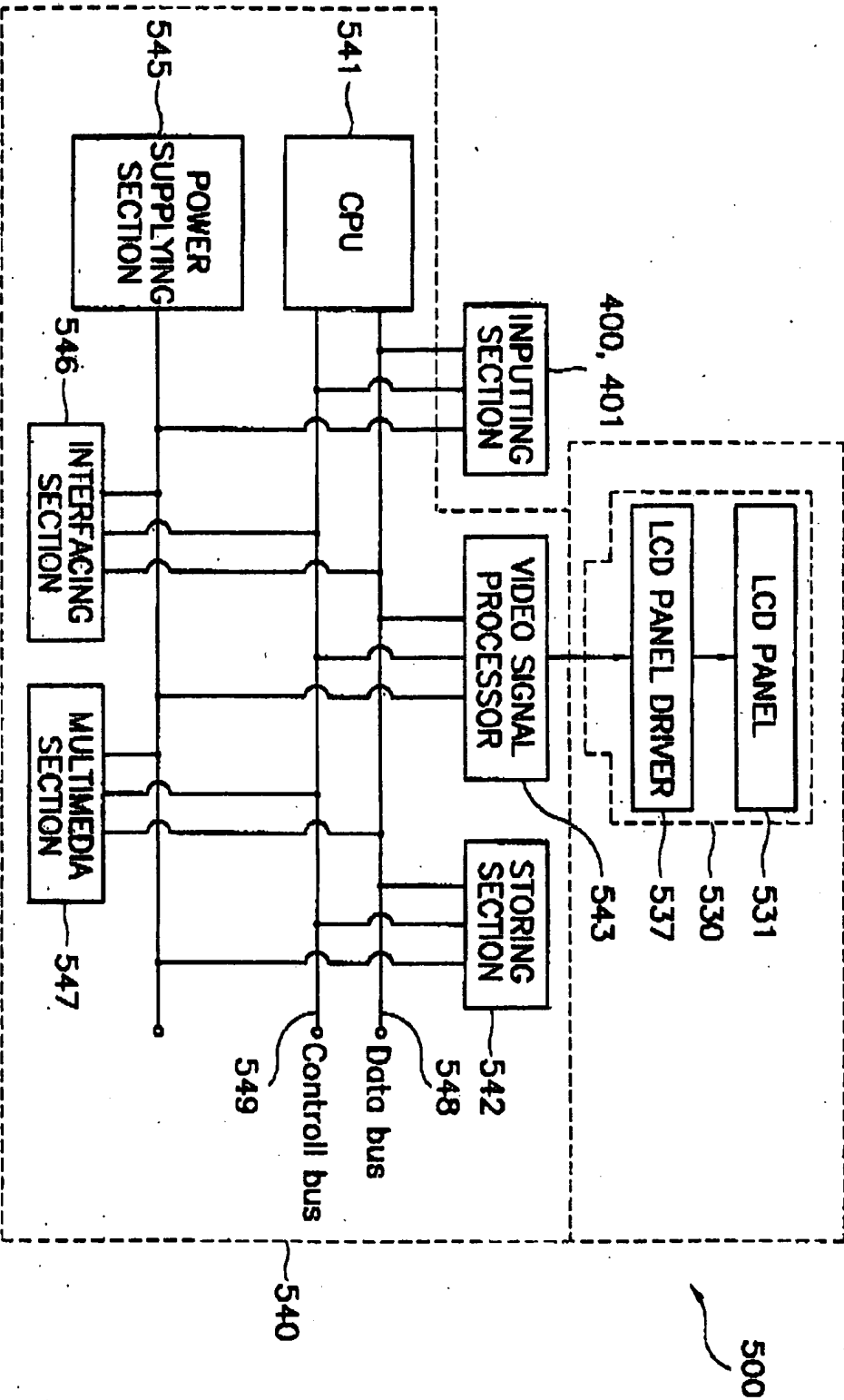

FIG. 11

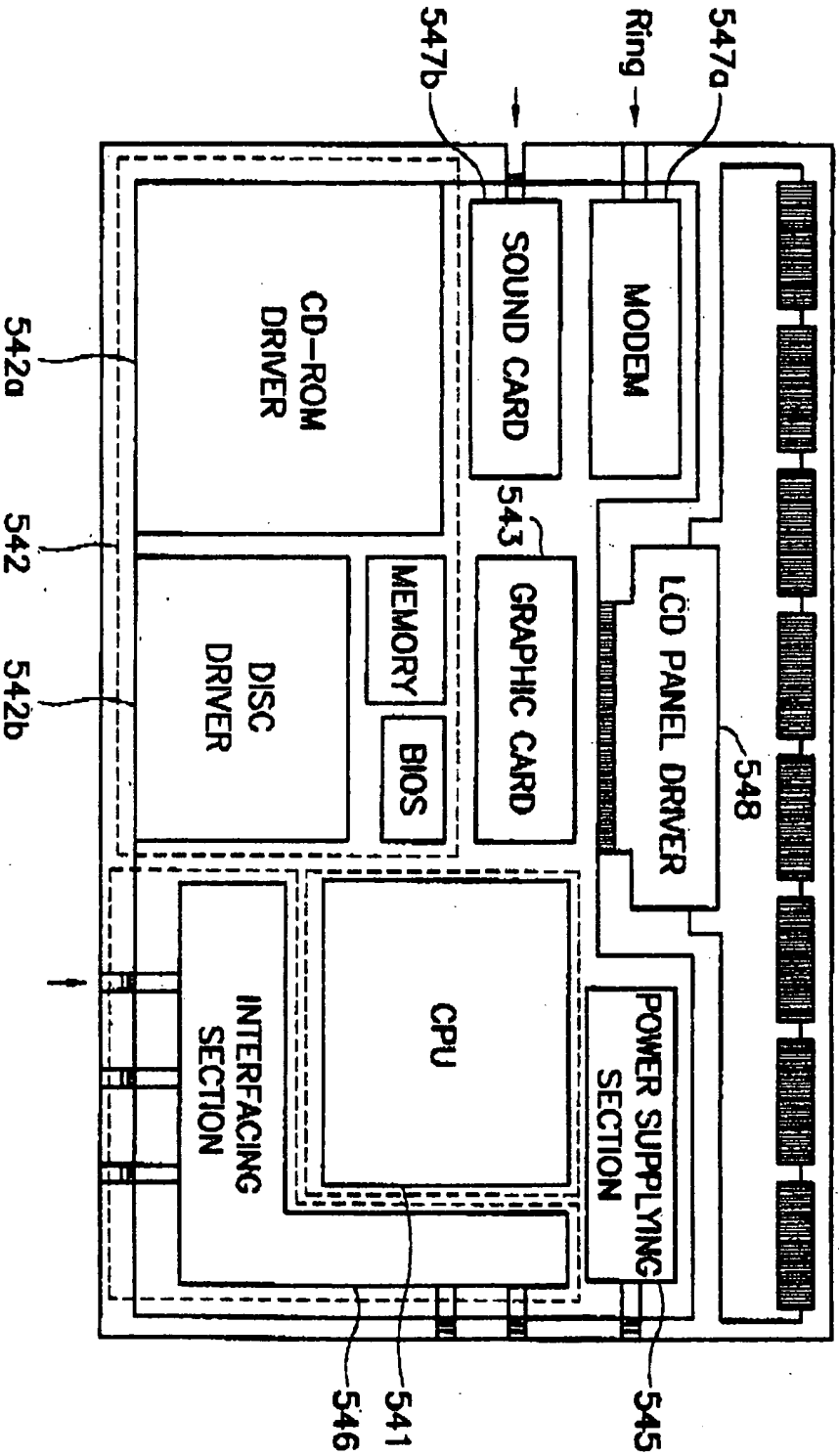
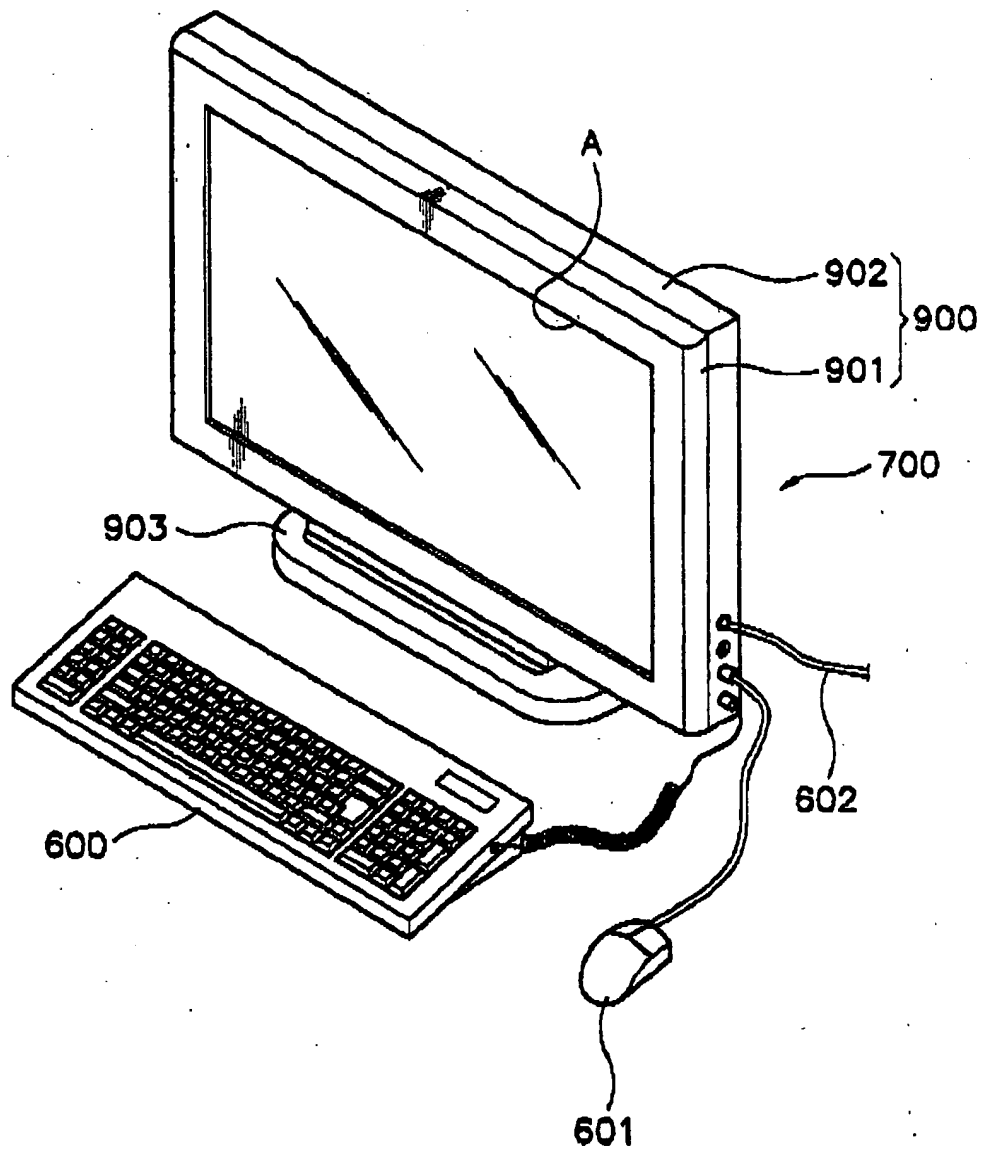

FIG. 12



00720" 528T 2560

FIG. 13

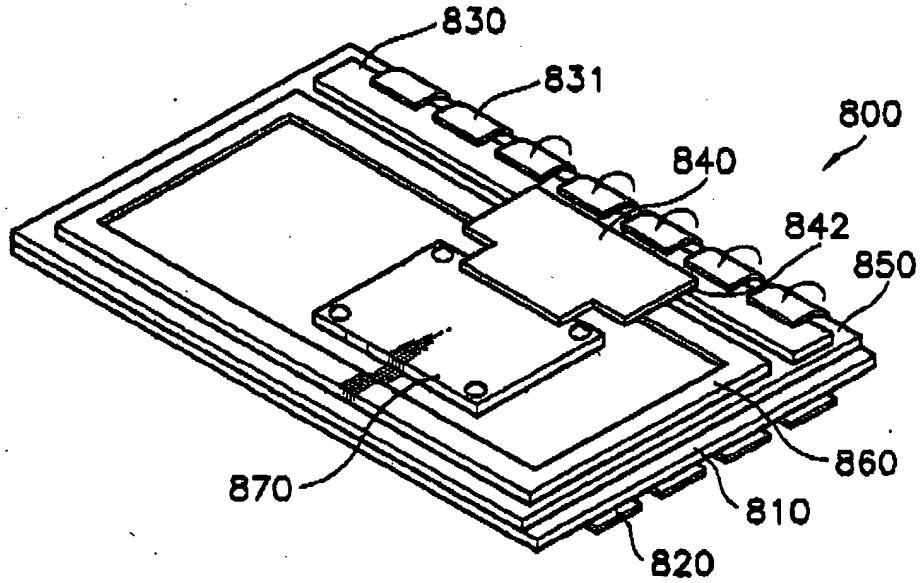

FIG. 14

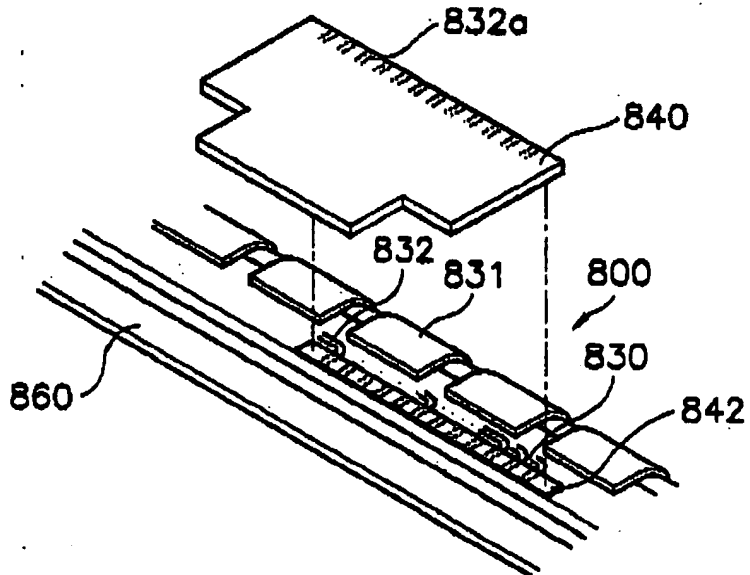

FIG. 15

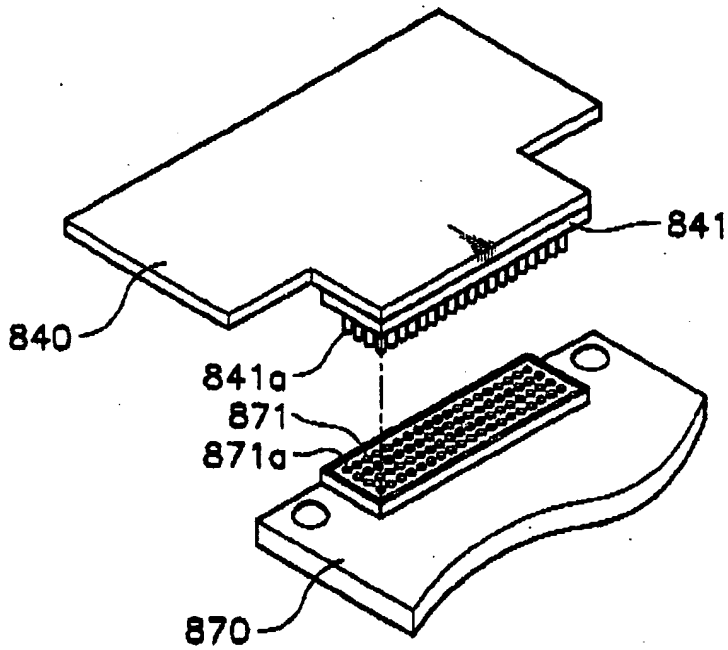

FIG. 16

